

PLATFORMS



# MSP 1232

Sputter solutions for high precision optical layers



# THE NEW MSP

MORE PRECISION,  
MORE THROUGHPUT &  
LOWER PRODUCTION COSTS

From smart consumer devices that keep us in touch 24/7 to head up displays or GPS satellite navigation systems that keep us safe on the road, our world relies on the mass production of high precision (HP) optical coatings.

The MSP batch sputter coater delivers new performance levels in sputter mass production with larger coating areas, higher throughputs, and higher precision over the complete coating area.



## SMART DEVICES



- Antireflection Coatings
- Hard Coatings
- Antismudge Coatings

## AUTOMOTIVE



- Head Up Display (HUD)
- ACC Adaptive cruise control
- Night vision systems

## LED TECHNOLOGY



- DBR Reflector Layers
- TCO Current Carrying Layers
- Contacts

## LIGHTING



- Dichroic colour filters
- Beam Splitters
- Reflectors

## MEDICAL



- Filter and mirror technologies for controlled heat and lighting conditions

## COMMUNICATIONS



- Antireflection Coatings
- Bandpass Filters

# MSP MEANS MORE POSSIBILITIES



*Integrated plasma source enables precleaning or new coating process options*



*Flexible drum carrier with usable coating area up to 2.2m<sup>2</sup>*

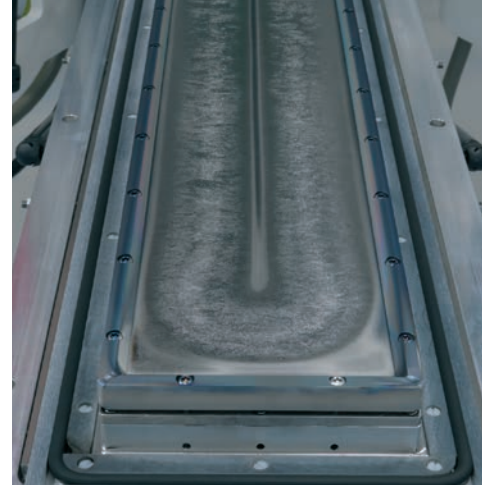

*Integrate up to 6 cathodes for more sputter material options*

# MORE...

## **SPUTTER CAPABILITY**

- Up to 6 cathodes in DC / Dual Magnetron Operation
- Deposition of TCOs, dielectrics and metals

## **LAYERS**

- Higher Stack thickness up to >20µm without compromise in stability
- Better surface qualities

## **PROCESS CHOICES**

- Integrate pre-cleaning steps
- Add DLC or antismudge layers
- Achieve better adhesion on plastics

## **CONTROL**

Advanced Process Control (APC) technology for:

- Shift free coatings with edge repeatabilities <0.2% in mass production

## **FLEXIBILITY**

- Simple exchange between substrate sizes
- Up to a maximum of 560 x 380mm with better uniformity than ever

## **THROUGHPUT**

- The MSP 1232 offers useable area of 2.2m<sup>2</sup> without compromise in optical performance
- Longer target lifetimes, quicker target changes

# MSP MEANS MORE PRODUCTIVITY

MSP's combination of system architecture and cathode technologies is designed for true mass production of high precision (HP) optical stacks. Swapping between different production processes is easy, with no set up time or test runs. Elimination of internal uniformity masks means higher deposition rates, no shedding and no particles for the best cosmetics

Evatec's production proven KHAN system and process controller gives you real time and historical trending run data from 25 user selected values for quality control.

# MSP MEANS MORE UPTIME

The new MSP design means access for all control racks and maintenance via the grey room with no disruption to clean room operations. Maintenance actions themselves have been reduced to a minimum with no shields to swap out. Hinged source access means rapid target change for the sputter sources or grid changes for the plasma source.

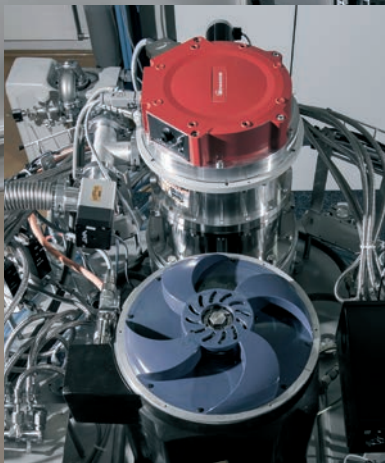
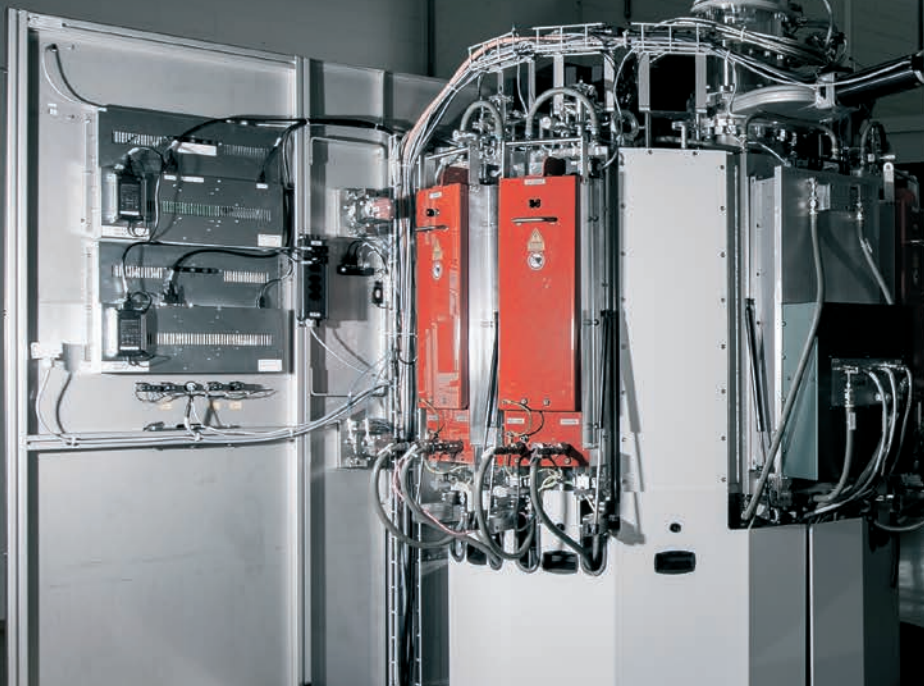

**Twin turbo pumping** configuration on chamber top and bottom for rapid pumping with easy access for maintenance.

# ADVANCED PROCESS CONTROL (APC) FOR THE BEST OPTICAL LAYERS

Evatec's proven rectangular sputter cathode technology lies at the heart of the MSP. The tunable magnet systems keep uniformity under control over the whole target life for maximum utilisation.

Advanced Process Control (APC) technologies specifically for high precision optical coatings enable your technology roadmap. Whether its developing complete new complex processes, or enhancing production yields for lower production costs, MSP with "Optics Toolbox" at its heart keeps your processes on track.

## "OPTICS TOOLBOX"

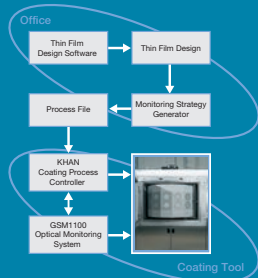

### Delivers fast track process development

- Integrate all steps from initial theoretical film design to final coating recipe generation
- Eliminate errors and accelerate development

## BROADBAND OPTICAL MONITORING

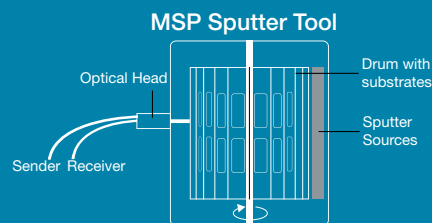

### Broadband monitoring for layer termination

- Complex stacks in UV, VIS and NIR
- Direct substrate measurement and control

## IN SITU REOPTIMISATION

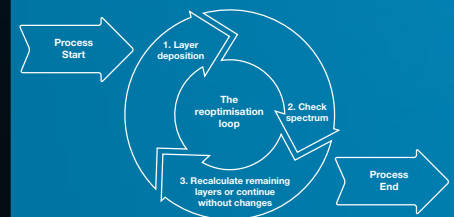

### Automatic "tuning" of your thin film recipe during deposition

- Reduce process set up times
- Achieve narrower tolerances
- Recover from unexpected errors, e.g. power outages

## PLASMA EMISSION MONITORING



### Precise control of film stoichiometry for the most repeatable optical properties

- Closed loop control at high deposition rates
- Full tool integration

## UNI- TUNE



### Uniformity adjustment without shapers

- Achieve  $< \pm 1\%$  uniformity over whole target life
- Simple adjustment during pumpdown

# EVATEC - ENABLING YOUR ROADMAP IN OPTICAL COATINGS

The MSP 1232 batch sputter platform with its flexible manual loading system is just one of the platforms available from Evatec for thin film applications in Photonics. Our process specialists combine 70 years of experience in evaporation technology and the latest know-how in sputter with Advanced Process Control technologies. They can guide you with the best choice of coating technology and platform architecture for your own individual application and throughput.

Alongside the **MSP 1232** our team can offer the **BAK** evaporator family, with manual or autoloader options, the **CLUSTERLINE®** cassette to cassette sputter platform with batch process module, or the **SOLARIS®** inline sputter platform.

Why not contact our applications team today by visiting <https://evatecnet.com/about-us/contact-us> and find out the best platform to meet your own needs.

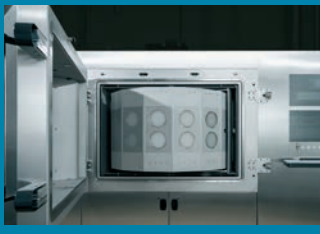
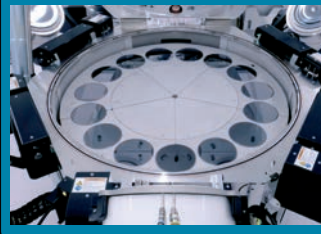
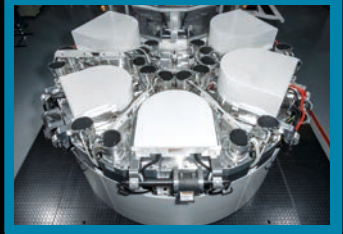
**MSP 1232****BAK****CLUSTERLINE®****SOLARIS®**

# MSP

## SPUTTER SOLUTIONS FOR HIGH PRECISION OPTICAL LAYERS

### TYPICAL LAYOUT

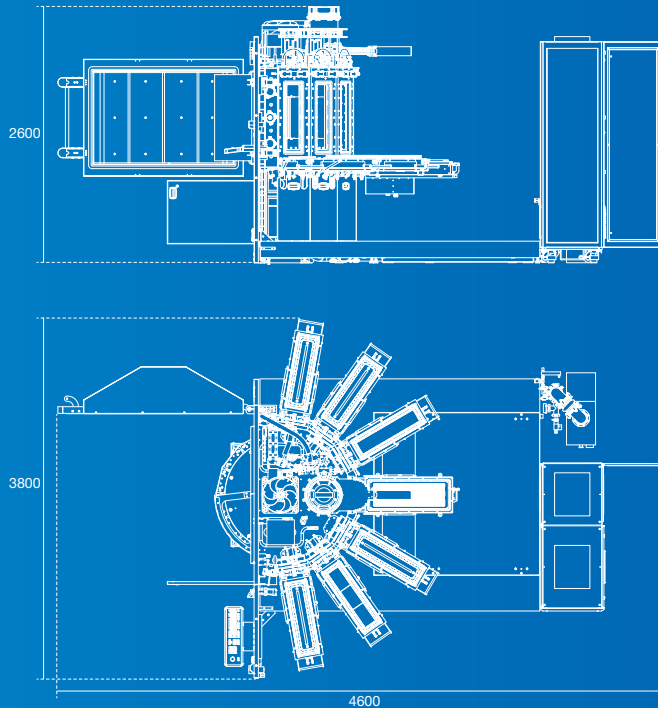

### TYPICAL SYSTEM CAPACITIES

The MSP 1232 tool provides precision in edge position over the whole coating drum.

Substrate size	MSP 1232
4" / 100mm	160
6" / 150mm	66
8" / 200mm	32
10" / 250mm	24
12" / 300mm	10
110 x 180mm	90
136 x 180mm	72
136 x 270mm	48

### ABOUT EVATEC

Evatec offers complete solutions for thin film deposition and etch in the optical and semiconductor markets. Evatec engineers are able to offer practical production advice from R&D to prototyping and mass production. We recognize that no single technique offers the answer to all problems.

With a technology portfolio including standard and enhanced evaporation as well as sputter, we are ready to offer sampling services and custom engineering to meet our customers individual needs.

We provide sales and service through our global network of local offices. For more information visit us at [www.evatecnet.com](http://www.evatecnet.com) or contact our head office.



**Evatec AG**  
Hauptstrasse 1a  
CH-9477 Trübbach  
Switzerland

Tel: + 41 81 403 80 00  
Fax: + 41 81 403 80 01  
[info@evatecnet.com](mailto:info@evatecnet.com)  
[www.evatecnet.com](http://www.evatecnet.com)

Product descriptions, photos and data are supplied within the brochure for general information only and may be superseded by any data contained within Evatec quotations, manuals or specifications.

Edition 5: Printed November 2022 (edition 4: first printed June 2021, edition 3 first printed February 2019, edition 2 first printed May 2016, Edition 1 first printed June 2015).